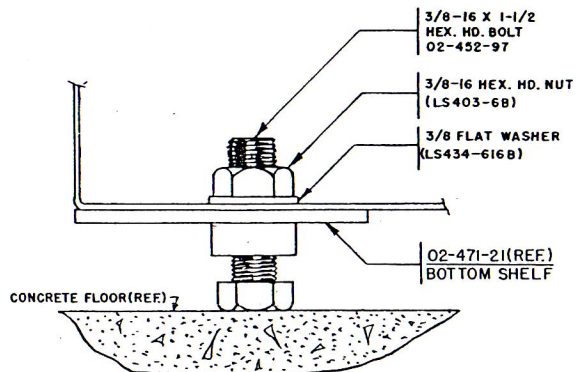
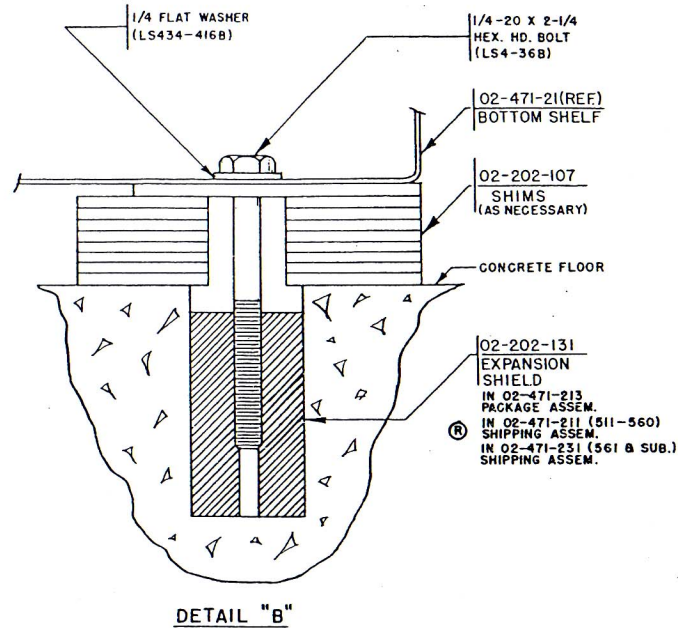

FIG. 3



DETAIL "A"

Lustron
CORPORATION

ERECTION		MANUAL	
TITLE BROOM CABINET ASSEM. & DET'S.			
RELEASE NO. NP-678	DATE 6-6-49	PREPARED BY W.C.G.	DATE 4-20-49
RELEASE NO. NP-632	DATE 4-20-49	REVISOR R.L.S.	DATE 6-6-49
EFF. 511 & SUB.		DRAWING NUMBER EM-O2-Q-11.11	