

SERVICE ENTRANCE
INSTALLATION

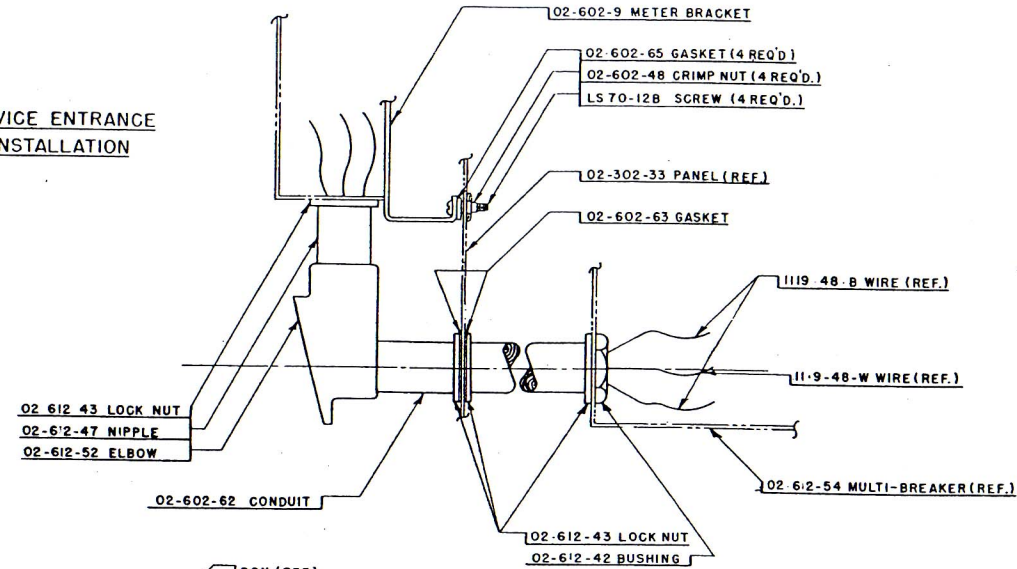

BOX TO BE INSTALLED TO LEAVE LIGHT FIXTURE
MOUNTING STRIP IN HORIZONTAL POSITION.

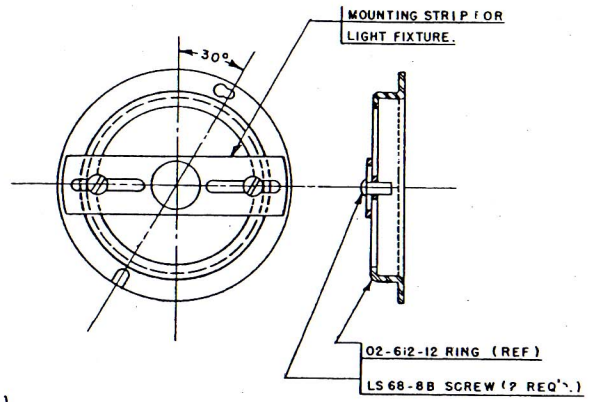

TYPICAL INSTALLATION FOR
EXTERIOR & HALL FIXTURES.

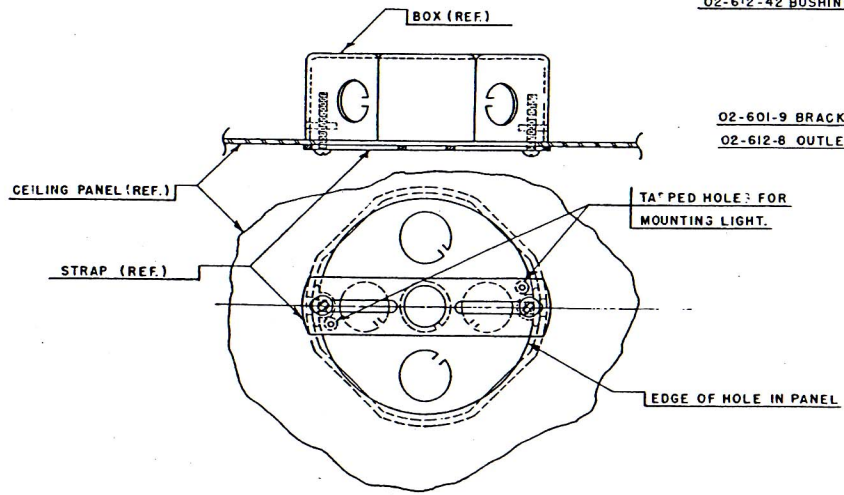

TYPICAL INSTALLATION FOR
ALL CEILING FIXTURES.

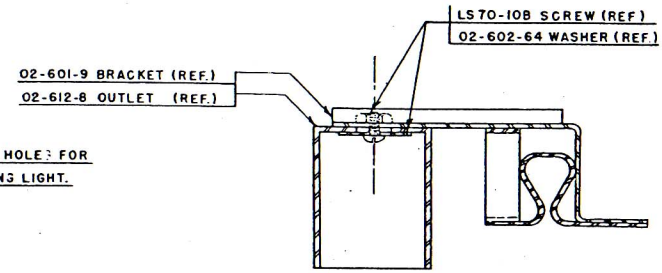

TYPICAL INSTALLATION FOR ALL
OUTLET BOXES NO 02-612-8.



ERECTION		MANUAL
TITLE ELECTRIC SERVICE INSTALLATION DETAILS		
PREPARED BY R H G	DATE 1-19-49	EFF. 11 & SUB. DRAWING NUMBER EM-02-K-50.1